

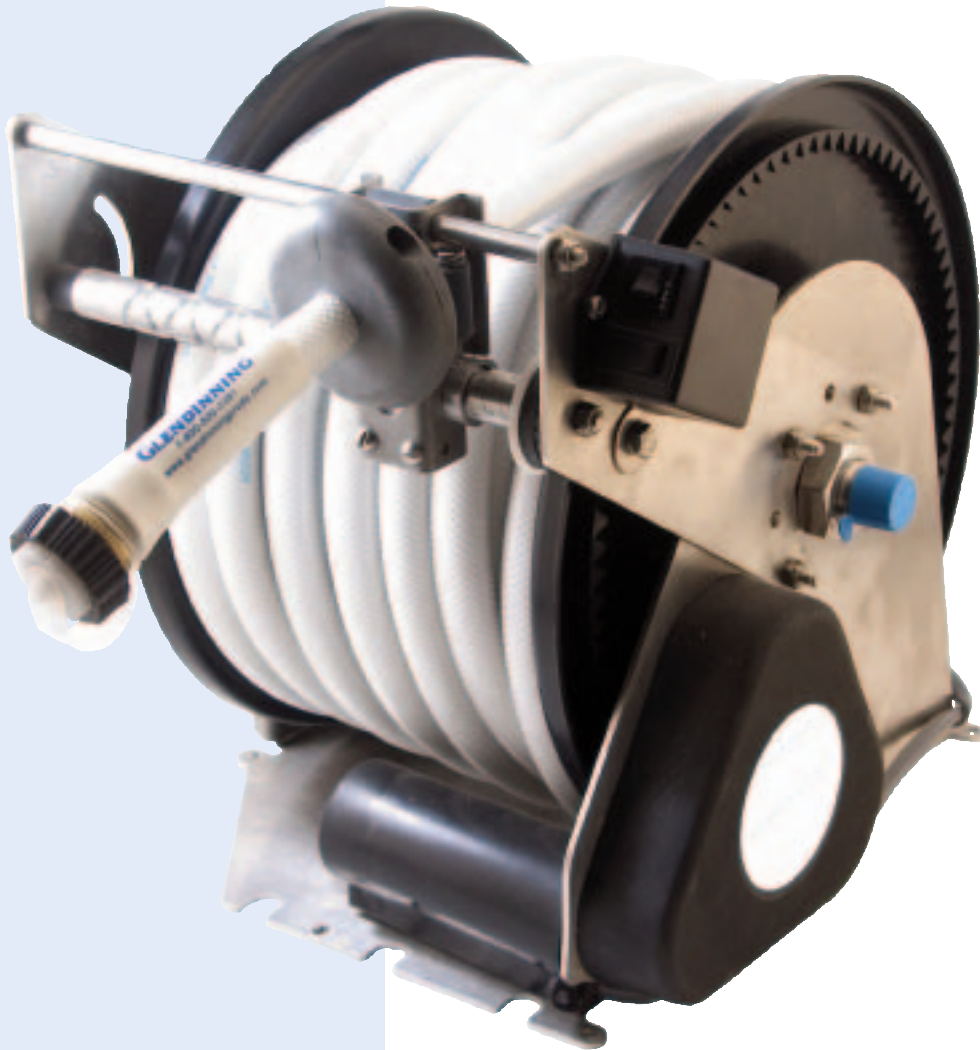

# HOSEMASTER™

Retrieve and store your water hose with push-button ease!



- **RETRACTS & STORES** up to 75 feet of 5/8" water hose

- **EASY MANUAL EXTENSION** means no "tug-of-war" feeling as with spring loaded reels

- **POWERED RETRIEVAL** just push the button and your water hose is retracted and stored with no effort

- **STANDARD** garden hose fitting connection



***"Relax . . . we're on board!"***

# STORING YOUR WATER HOSE HAS NEVER BEEN EASIER!

Why mess around with an uncooperative hose? The Glendinning Hosemaster™ puts an end to fighting with your water hose during storage. With easy manual effort you can extend as much hose as is necessary for the task at hand — and when you're done, the Hosemaster™ will automatically retract and store your water hose with push-button ease. The Hosemaster™ has a number of features that make it the only answer for your water hose storage problems!

## FEATURES & BENEFITS

- **POWERED RETRACTION** — Simply push the button and the Hosemaster™ will automatically coil and store up to 75 feet of 5/8" water hose.
- **ELIMINATES THE MESS** — If you've ever tried to coil up your hose after use, you know how often you get wet and how uncooperative your hose can be — not to mention how much space it takes up.
- **LISTED FOR POTABLE WATER APPLICATIONS** — can also be configured for use with other hoses or cords.
- **STAINLESS STEEL CONSTRUCTION** — The Hosemaster™ is made of stainless steel and plastic, materials that hold up under harsh conditions where corrosion is a problem.
- **FITS VIRTUALLY ANYWHERE** — The compact design of the Hosemaster™ allows it to be installed in the most space challenged areas.
- **ADJUSTABLE HOSE GUIDE** — This feature allows the unit to be mounted in a variety of positions for greater flexibility during installation.

### HOSEMASTER™ SPECIFICATIONS

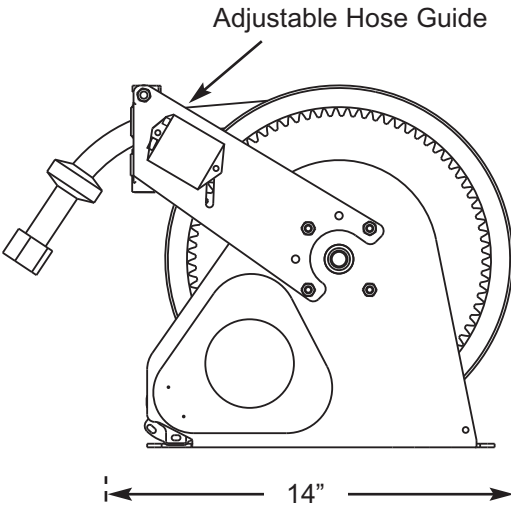

Adjustable Hose Guide

14"

13"

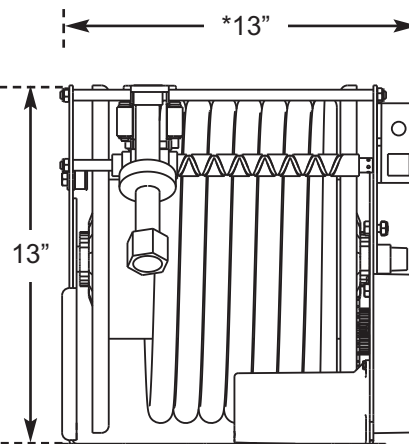

\*13"

13"

\* — add min. 1" to allow for elbow installation connection

<b>PART NO.</b>	05520 —12VDC— 75 feet / 5/8"
	05521 —24VDC— 75 feet / 5/8"
	05522 —12VDC— 100 feet / 1/2"
	05523 —24VDC— 100 feet / 1/2"
<b>CURRENT (RETRACTION):</b>	.....3-4 amps
<b>OVERLOAD PROTECTION:</b>	.....included
<b>WATER CONNECTION:</b>	.....1/2" NPT
<b>HOSE TYPE:</b>	.....White non-marking, ..... <i>DRINKING WATER SAFE</i>
<b>WEIGHT:</b>	.....under 27 lbs.



**MADE IN THE USA**

*For more information, contact our sales engineer or your local dealer today!*



740 Century Circle  
Conway, SC 29526

Phone: (843) 399-6146  
Fax: (843) 399-5005

[www.glendinningprods.com](http://www.glendinningprods.com)  
HMB2\_V2.0 03/07